

## Gremotool Jaws

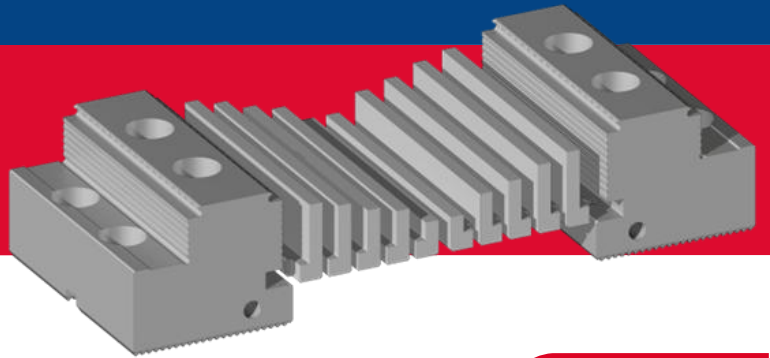

swiss  
made 



# Overview

## Jaws

---

<b>Overview</b>	<b>2</b>
<b>Product presentation</b>	<b>4</b>
<b>Series of jaws</b>	<b>8</b>
<b>Type overview</b>	<b>9</b>
Interchangeable Jaws	9
Standard Jaws	10
Height calculation of clamping systems	11
<b>Table of jaws interchangeable</b>	<b>12</b>
Base body interchangeable jaw	12
Gripper jaw interchangeable	13
Stepped jaw interchangeable G=19	14
Stepped jaw interchangeable G=14	15
Stepped jaw interchangeable G=9	16
Stepped jaw interchangeable G=4	17
Interchangeable rough jaw in steel	18

---

<b>Table of jaws standard</b>	<b>19</b>
SC-LC gripping jaw low	19
Standard SC-LC gripper jaw	20
Standard PMC-HMC gripper jaw	21
Gripper jaw high	22
Combi Gripper jaw	23
Gripper jaw heigh one-sided	24
Stepped jaw high one sided	25
Step jaw low	26
Step jaw	27
Step jaw high one-sided	28
Prism jaw	29
Soft jaw Aluminium	30
Soft jaw Steel	31
<b>Applications</b>	<b>32</b>
<b>Accessories</b>	<b>34</b>
<b>Imprint</b>	<b>40</b>

# Product presentation

## Jaws

The Gremotool jaws are used to hold workpieces securely in the clamping device. They have to fulfil several tasks at the same time. The jaws must hold the workpiece securely in position with the available force of the clamping device and be designed in such a way that accessibility to the workpiece is optimised. They must also be flexible enough to be used with all Gremotool clamps, even if the width of the clamping device does not match the width of the jaws.

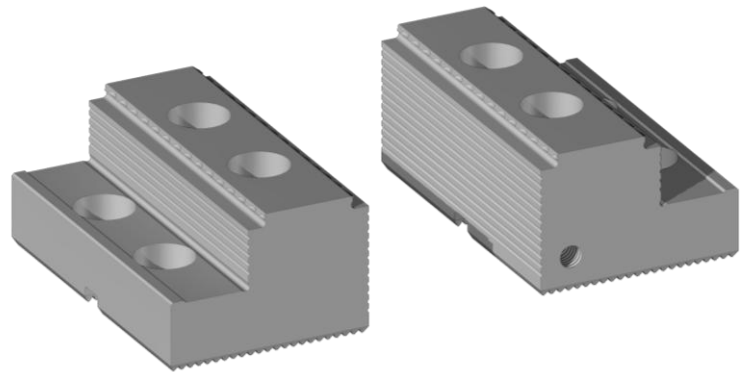

# Product presentation

## Clamping

### Workpiece fixing

The target of every clamping device is to fix the workpiece precisely and firmly in place without deforming it too much. To achieve this in every case, the Gremotool clamps can be equipped with different jaw types across all series and sizes.

### Gripper Clamping

If sawn, drawn, forged and rectangular workpieces need to be clamped and all sides machined, it is advisable to use gripper jaws for the initial clamping. The Gremotool gripper jaws fix the workpiece with several gripper that grip into the material. The geometry of the gripper leads to a pull-down effect and the component rests cleanly on the jaw. The low design of the gripper means that only a small amount of allowance is required on the raw material dimension, which significantly reduces material requirements.

### Surface clamping

If no marks are to be made on the clamping surfaces during clamping, stepped jaws can be used. These jaws are flat and do not damage the workpiece. Nevertheless, they fix the workpiece precisely and firmly on the clamping device.

### Round workpieces

Prism jaws are used so that round workpieces can be fixed in the centre of a 2-jaw clamp. Thanks to their V-shaped cut, the workpieces are automatically clamped precisely in the centre of the jaws. This is guaranteed with the Gremotool jaws in both horizontal and vertical positioning.

### Clamping in the correct shape

If the workpiece does not have parallel surfaces for clamping, soft jaws can be used. The contours of the workpiece are milled into these soft jaws before the workpiece is clamped. This allows the workpiece to be clamped along the entire contour that lies within of the jaws.

### Positioning on jaws

To ensure that the workpieces can be inserted correctly around the circumference of the series, threads are attached to the sides of the jaws. Workpiece stops can be attached to these threads or magnetically to the jaws. This simplifies zero-point determination and reduces set-up times.

### Delivered in pairs

All Gremotool jaws are delivered in pairs. This enables the clamping system to be used as fast as possible. All Gremotool clamping systems are delivered with the standard jaws. However, additional jaws can be requested in order to extend the range of applications and operate the maximum flexibility of the clamping system.

# Product presentation

## Advantages of Gremotool jaws

### Universal mounting system

The universal mounting system for the Gremotool clamping systems means that the jaws, products, and series can be used across the board.

The Gremotool jaws are divided into 4 groups, which ensure the interchangeability of the jaws. Within these groups, the jaws are interchangeable on the respective defined clamping systems.

Small part clamps	618
Small part clamps	628
Standard part clamps	828
Large part clamps	860

### Two-sided use

Some of the Gremotool jaws can be used on both sides. The step in the jaw allows the clamping range to be optimally utilised. The step also enables clamping on machined surfaces with the gripper jaws without damaging the workpiece.

### Fast Interchangeable Jaws

The Gremotool fast interchangeable jaw system is used to quickly adjust the jaws to the current clamping situation. This can be done with the robot or by hand. By simply clicking in the jaws, they are ready for clamping the workpieces after a single manual movement. The inclined plane ensures a pull-down effect so that the workpiece is always in the same position.

### Hard materials without pre-stamping

Forged or hard materials must be clamped with even harder materials so that they can grip into the workpiece. The Gremotool Gripp serration makes this possible without the need for a special device on which the material must be pre-stamped.

### Soft materials

The Gremotool Gripp grip securely and firmly into soft materials. They only lose their grip in the material when the clamping device is opened. If the clamping surface must remain undamaged, step jaws can be used. These hold the workpiece firmly in position and leave only marginally small marks on the workpiece.

### Various types

Gremotool range of jaws is just as varied as the range of workpieces. Gremotool jaws are available for every clamping requirement and if the catalogue range is not sufficient, please contact Gremotool, we are looking forward to recommend the right solution for you.

# Product presentation

## Follow-up treatment

**Indulaser AG** is a medium-sized Swiss company that has built an excellent name for itself in inductive heat treatment by innovation and maximum process reliability since 2002. We are a full-service provider and take care not only of the heat treatment, but also the pre- and post-treatment, so that you receive a finished part. Our all-round carefree package includes everything from parts cleaning and material analyses to packaging.

We offer the services separately from the overall process. In addition to heat treatment as our speciality, this also includes the production of series, prototypes, and individual parts. We are also delighted to assist you in the laboratory and in development. A unique feature of our process is the use of simulation software for heat treatment and 3D printing for the manufacture of product-specific tools.

Get in touch with us and we'll work together to find the perfect solution for you and your product.

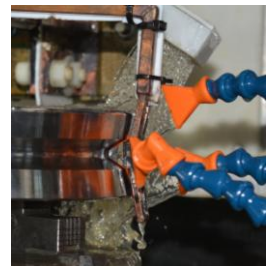

**Kasé Knives Switzerland** is specialised in the refinement of high-quality, resistant materials for industrial use. The focus here is on the use of extremely wear-resistant powder metallurgical special materials in conjunction with high-quality heat treatment methods. Gremotool gripper jaws, for example, are subjected to multiple cryogenic treatments and careful tempering in a temperature-homogeneous molten salt. Thanks to annealing protocols developed over many years, the maximum service life and toughness can be extracted from the steels used.

If you want to cut a good shape, Kasé Knives is the right choice for you!



# Series of jaws

Category of Gremotool clamping systems

Within the jaw groups 618, 628, 828 and 860, the jaws can be replaced without adjustments. If the jaws are to be changed beyond these groups, please contact us to check the technical feasibility.



Group	PMC	HMC	SC	VC	LC
<b>618</b>			SC-34 SC-40		LC-34 LC-40
<b>628</b>	PMC-50	HMC-50	SC-50		LC-50
<b>828</b>	PMC-60 PMC-60I PMC-74	HMC-60 HMC-60I HMC-74	SC-60 SC-74	VC-60 VC-74	LC-60 LC-74
<b>860</b>	PMC-100 PMC-120	HMC-100 HMC-120	SC-100 SC-120	VC-100 VC-120 VC-150	LC-100 LC-120 LC-150

# Type overview

## Interchangeable Jaws

### Interchangeable jaws

Changing the Gremotool interchangeable jaws is simple. The base jaws are firmly screwed onto the clamping system. The front insert can then be replaced with a manual movement or by the robot gripper. Several different jaw types are available, offering the right choice for every application.

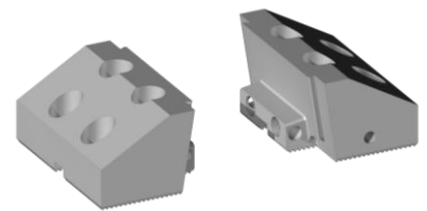
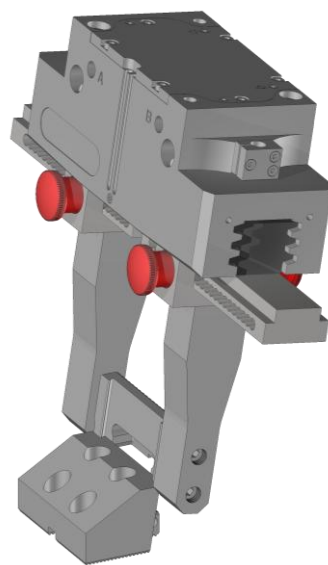

### Base body interchangeable jaws

Nr. 837900-BXX

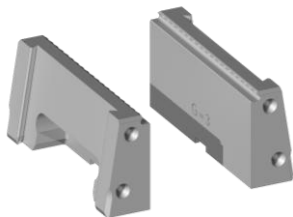

### Gripper jaw interchangeable

Nr. 835380-BXX

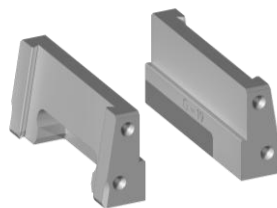

### Stepped jaw interchangeable G=19

Nr. 835481-BXX

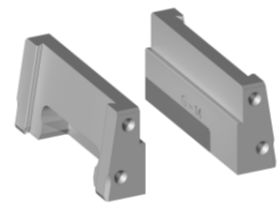

### Stepped jaw interchangeable G=14

Nr. 835482-BXX

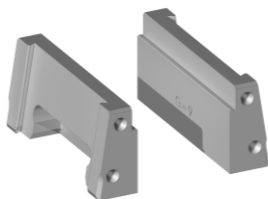

### Stepped jaw interchangeable G=9

Nr. 835483-BXX

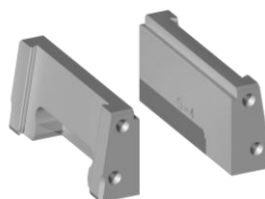

### Stepped jaw interchangeable G=4

Nr. 835484-BXX

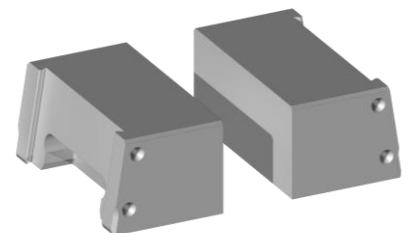

### Soft jaw steel interchangeable

Nr. 835703-BXX

# Type overview

## Standard Jaws

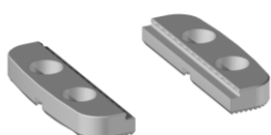

**SC-LC Gripper jaw low**  
Nr. 837110-BXX

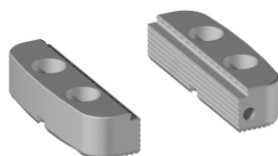

**Standard SC-LC Gripper jaw**  
Nr. 837150-BXX

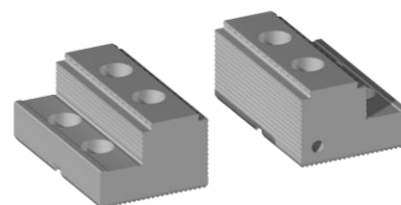

**Standard PMC-HMC Gripper jaw**  
Nr. 837250-BXX

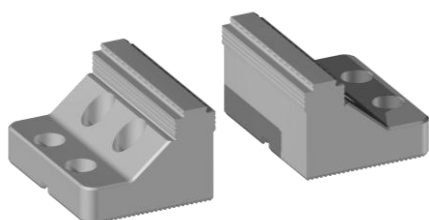

**Gripper jaw high**  
Nr. 837300-BXX

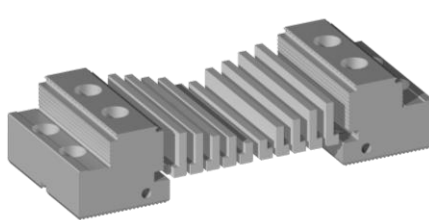

**Combi gripper jaw**  
Nr. 837350-BXX

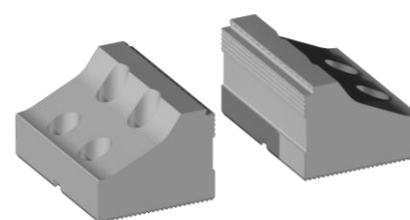

**Gripper jaw high one-sided**  
Nr. 837380-BXX

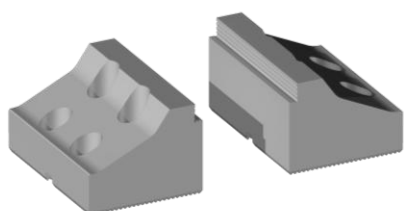

**Step jaw high one sided deep**  
Nr. 837400-BXX

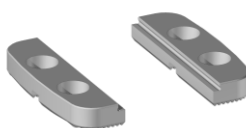

**Step jaw low**  
Nr. 837410-BXX

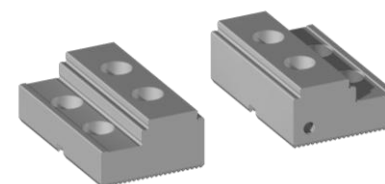

**Step jaw**  
Nr. 837450-BXX

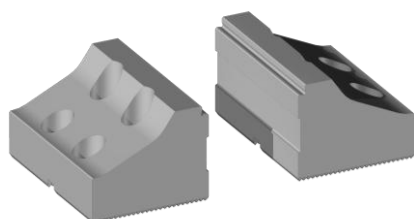

**Step jaw high one-sided**  
Nr. 837480-BXX

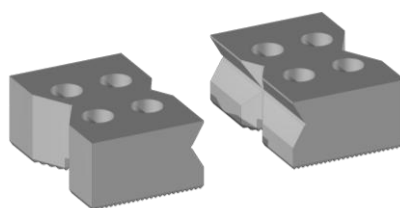

**Prism jaw**  
Nr. 837500-BXX

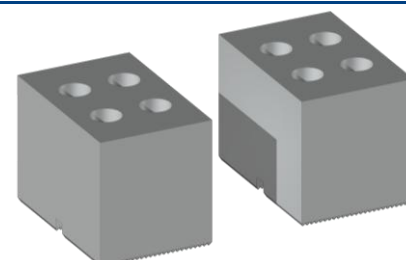

**Soft jaw aluminium / steel**  
Nr. 837702-BXX / 837703-BXX

# Type overview

Height calculation of clamping systems

Calculation example

	Type	Operator	Height [mm]
Clamping device	LC-60	+	62
Height of jaw	837250-B60	+	31
Height of gripper	837250-B60	-	3
<b>Total</b>		=	<b>90</b>

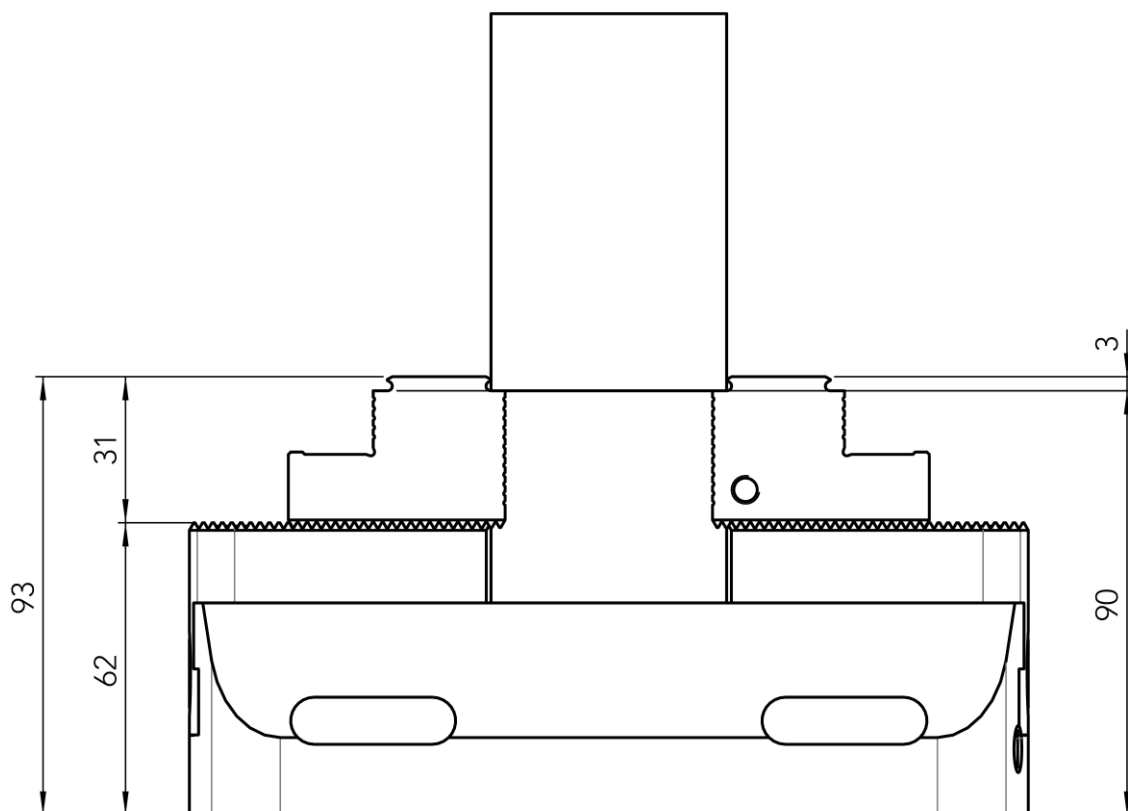

# Table of jaws interchangeable

## Base body interchangeable jaw

The base jaw interchangeable for the Gremotool jaw interchanging system can be combined with all clamping devices. The jaw inserts can be easily inserted and secured with a single hand movement. When clamping the workpieces, the inclined plane creates a pull-down effect. The workpieces are therefore always at the same depth and can be adapted to the clamping situation.

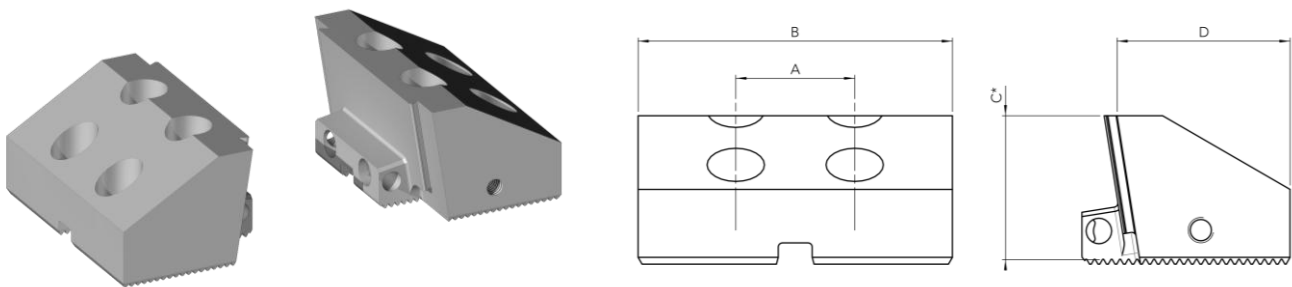

Order code	837900- B40	837900- B50	837900- B60	837900- B74	837900- B100	837900- B120	837900- B150
<b>A Series of jaws</b>	618	628	828	828	860	860	860
<b>B Jaw width</b> [mm]	40	50	60	74	100	120	150
<b>C Jaw height*</b> [mm]	34	34	34	34	34	34	34
<b>D Jaw length</b> [mm]	29	29	29	49	49	49	49

\* The jaw height is reduced by the gripping depth so that the actual height of the clamping system can be easily calculated.

# Table of jaws interchangeable

## Gripper jaw interchangeable

The gripper jaw interchangeable was specially developed for the change base jaw. This jaw has a very short design to enable a maximum clamping path of the clamping systems with short modules. The gripper toothing has a pull-down effect, which is reinforced by the inclined back. This means that the workpieces always rest at the same depth and are securely clamped.

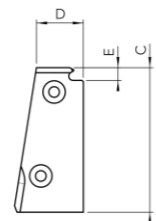
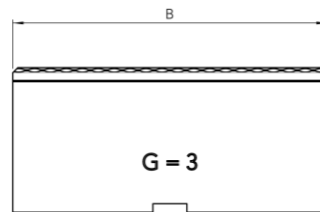
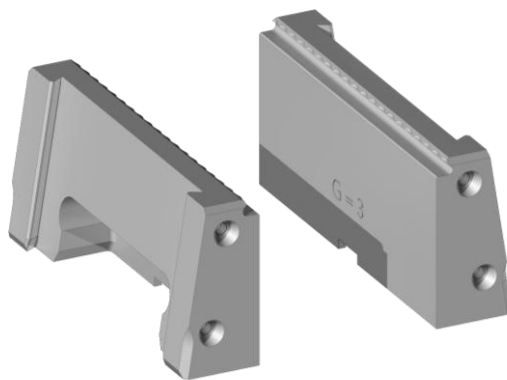

Order code		835380- B40	835380- B50	835380- B60	835380- B74	835380- B100	835380- B120	835380- B150
<b>B</b>	Jaw width [mm]	40	50	60	74	100	120	150
<b>C</b>	Jaw height [mm]	34	34	34	34	34	34	34
<b>D</b>	Jaw length [mm]	11.5	11.5	11.5	11.5	11.5	11.5	11.5
<b>E</b>	Gripper height [mm]	3	3	3	3	3	3	3

# Table of jaws interchangeable

## Stepped jaw interchangeable G=19

The stepped jaws interchangeable are the first choice when it comes to surface clamping on machined surfaces. The step enables a level insertion and the clamping surfaces a strong fixation of the workpiece. Different step heights can be selected with the different order numbers, depending on the application.

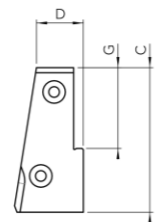
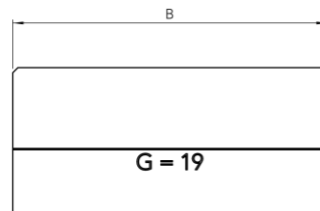
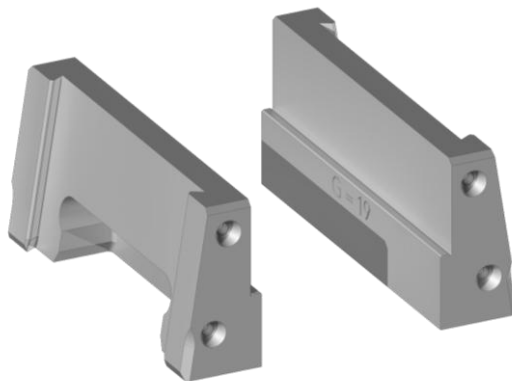

Order Code	835481- B40	835481- B50	835481- B60	835481- B74	835481- B100	835481- B120	835481- B150
<b>B</b> Jaw width [mm]	40	50	60	74	100	120	150
<b>C</b> Jaw height [mm]	34	34	34	34	34	34	34
<b>D</b> Jaw length [mm]	11	11	11	11	11	11	11
<b>G</b> Step height [mm]	19	19	19	19	19	19	19

# Table of jaws interchangeable

## Stepped jaw interchangeable G=14

The stepped jaws interchangeable are the first choice when it comes to surface clamping on machined surfaces. The step enables a level insertion and the clamping surfaces a strong fixation of the workpiece. Different step heights can be selected with the different order numbers, depending on the application.

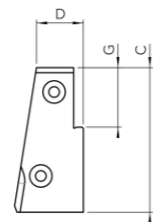
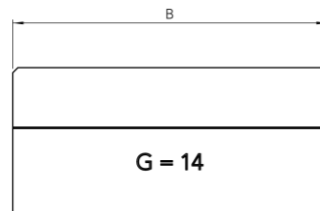
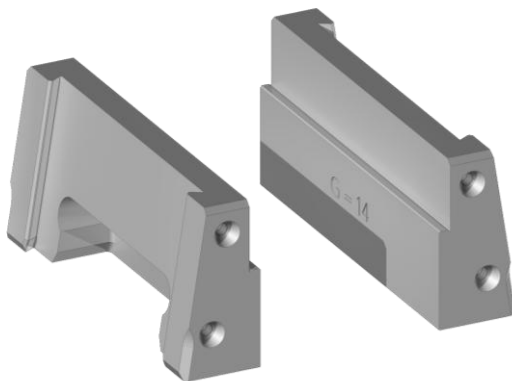

Order Code	835482- B40	835482- B50	835482- B60	835482- B74	835482- B100	835482- B120	835482- B150
<b>B</b> Jaw width [mm]	40	50	60	74	100	120	150
<b>C</b> Jaw height [mm]	34	34	34	34	34	34	34
<b>D</b> Jaw length [mm]	11	11	11	11	11	11	11
<b>G</b> Step height [mm]	14	14	14	14	14	14	14

# Table of jaws interchangeable

## Stepped jaw interchangeable G=9

The stepped jaws interchangeable are the first choice when it comes to surface clamping on machined surfaces. The step enables a level insertion and the clamping surfaces a strong fixation of the workpiece. Different step heights can be selected with the different order numbers, depending on the application.

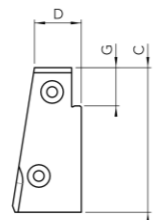
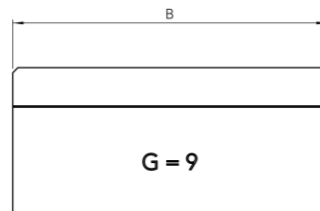
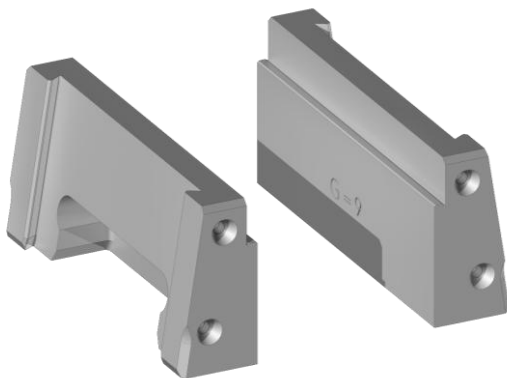

Order Code	835483- B40	835483- B50	835483- B60	835483- B74	835483- B100	835483- B120	835483- B150
<b>B</b> Jaw width [mm]	40	50	60	74	100	120	150
<b>C</b> Jaw height [mm]	34	34	34	34	34	34	34
<b>D</b> Jaw length [mm]	11	11	11	11	11	11	11
<b>G</b> Step height [mm]	9	9	9	9	9	9	9

# Table of jaws interchangeable

## Stepped jaw interchangeable G=4

The stepped jaws interchangeable are the first choice when it comes to surface clamping on machined surfaces. The step enables a level insertion and the clamping surfaces a strong fixation of the workpiece. Different step heights can be selected with the different order numbers, depending on the application.

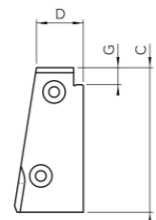
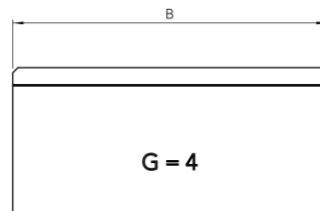
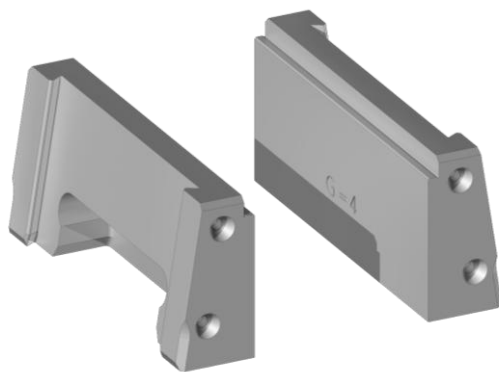

Order Code		<b>835484- B40</b>	<b>835484- B50</b>	<b>835484- B60</b>	<b>835484- B74</b>	<b>835484- B100</b>	<b>835484- B120</b>	<b>835484- B150</b>	
<b>B</b>	<b>Jaw width</b>	[mm]	40	50	60	74	100	120	150
<b>C</b>	<b>Jaw height</b>	[mm]	34	34	34	34	34	34	34
<b>D</b>	<b>Jaw length</b>	[mm]	11	11	11	11	11	11	11
<b>G</b>	<b>Step height</b>	[mm]	4	4	4	4	4	4	4

# Table of jaws interchangeable

## Soft jaw steel interchangeable

The soft jaw steel interchangeable are suitable for the in-house production of clamping jaws. Negative contours or mountings for additional clamping elements can be easily incorporated into the steel jaws. As a result, this type of jaw can be used for a wide variety of tasks and workpieces. Subsequent hardening is possible in order to maximize the wear resistance of the jaws.

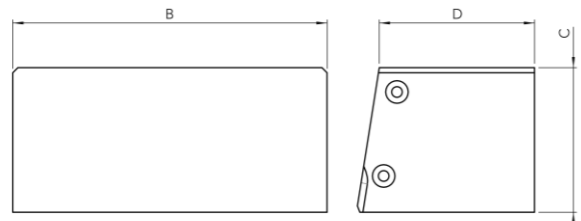
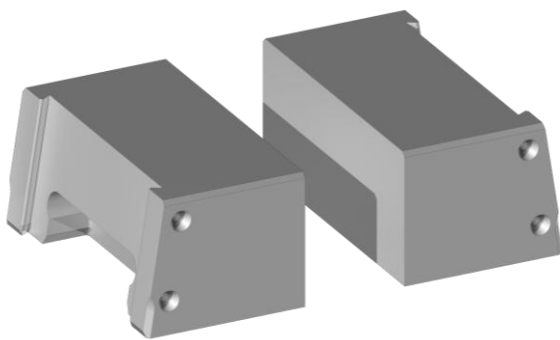

Order code	<b>835703- B40</b>	<b>835703- B50</b>	<b>835703- B60</b>	<b>835703- B74</b>	<b>835703- B100</b>	<b>835703- B120</b>	<b>835703- B150</b>
<b>B Jaw width</b> [mm]	40	50	60	74	100	120	150
<b>C Jaw height</b> [mm]	34	34	34	34	34	34	34
<b>D Jaw length</b> [mm]	36.5	36.5	36.5	36.5	36.5	36.5	36.5

# Table of jaws standard

## SC-LC gripping jaw low

The SC-LC low gripper jaw was specially developed for the SC and LC series. This jaw has a very short design to maximise the clamping distance of the clamping systems. The jaw is also kept low so that the workpiece is in the lowest possible position for machining.

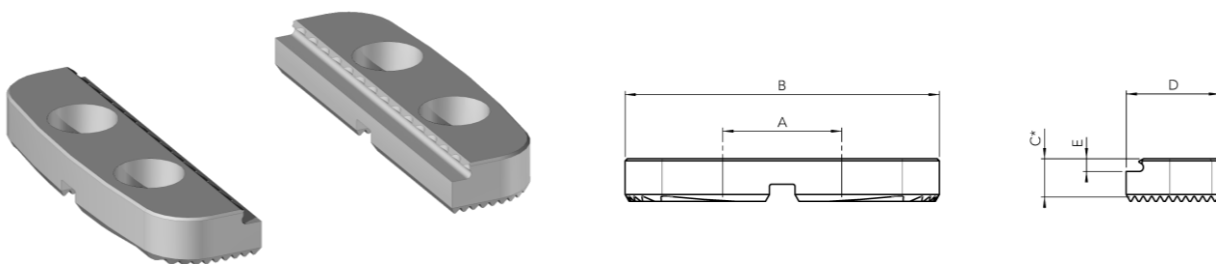

Order code	837110- B34	837110- B40	837110- B50	837110- B60	837110- B74	837110- B100	837110- B120	837110- B150
<b>A Series of jaws</b>	618	618	628	828	828	860	860	860
<b>B Jaw width</b> [mm]	34	40	50	60	74	100	120	150
<b>C Jaw height*</b> [mm]	7	7	7	9	9	11	11	11
<b>D Jaw length</b> [mm]	17	17	21	21	22	22	26	26
<b>E Gripper height</b> [mm]	3	3	3	3	3	3	3	3

\* The jaw height is reduced by the gripping depth so that the actual height of the clamping system can be easily calculated.

# Table of jaws standard

## Standard SC-LC gripper jaw

The standard SC-LC gripper jaw has been specially designed for the SC and LC series. The very short jaws with a gripping serration side enable maximum clamping range of the clamping systems. Accessibility for machining is optimised for current machining methods thanks to the shape of the jaws.

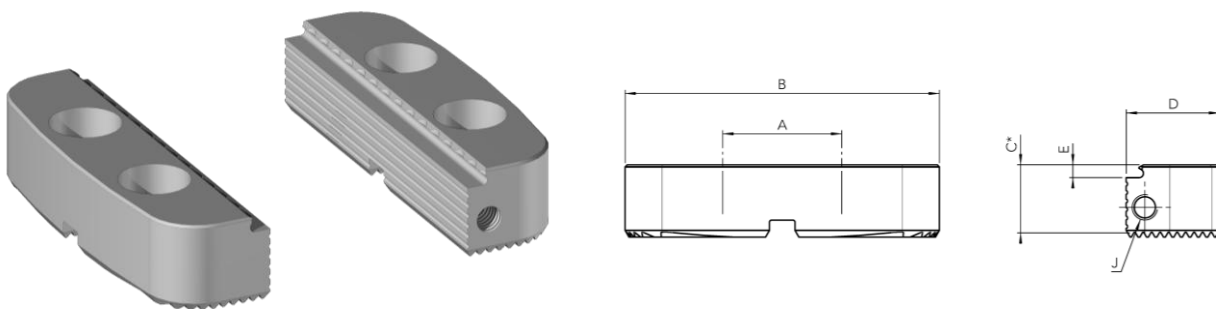

Order code	837150- B34	837150- B40	837150- B50	837150- B60	837150- B74	837150- B100	837150- B120	837150- B150
<b>A Series of jaws</b>	618	618	628	828	828	860	860	860
<b>B Jaw width</b> [mm]	34	40	50	60	74	100	120	120
<b>C Jaw height*</b> [mm]	12	12	12	16	16	15	15	15
<b>D Jaw length</b> [mm]	17	17	21	21	22	22	26	26
<b>E Gripper height</b> [mm]	3	3	3	3	3	3	3	3
<b>J Side thread**</b>	M5	M5	M5	M6	M6	M6	M6	M6

\* The jaw height is reduced by the gripping depth so that the actual height of the clamping system can be easily calculated.

\*\* Side thread for workpiece stop

# Table of jaws standard

## Standard PMC-HMC gripper jaw

The standard PMC-HMC gripper jaw has been developed for the high clamping forces of pneumatic and hydraulic clamping systems. Despite their height, they are designed for maximum stability and precise holding of the workpiece. In order not to restrict the clamping range, the jaws have gripping grippers on both sides and a step for surface clamping.

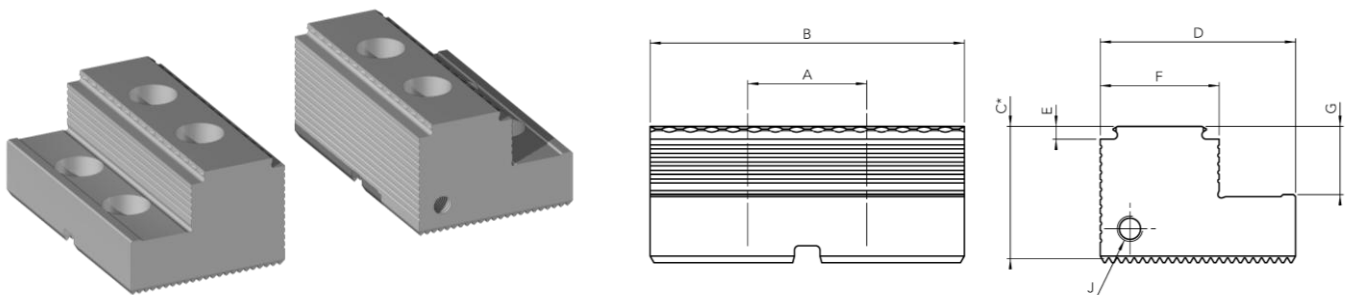

Order code	837250- B34	837250- B40	837250- B50	837250- B60	837250- B74	837250- B100	837250- B120	837250- B150
<b>A Series of jaws</b>	618	618	628	828	828	860	860	860
<b>B Jaw width</b> [mm]	34	40	50	60	74	100	120	150
<b>C Jaw height*</b> [mm]	14	14	16	31	31	34	34	34
<b>D Jaw length</b> [mm]	26	26	26	46	46	48	48	48
<b>E Gripper height</b> [mm]	3	3	3	3	3	3	3	3
<b>F Step length</b> [mm]	20	20	20	28	28	28	28	28
<b>G Step height</b> [mm]	7	7	9	15	15	15	15	19
<b>J Side thread**</b>	M5	M5	M5	M6	M6	M6	M6	M6

\* The jaw height is reduced by the gripping depth so that the actual height of the clamping system can be easily calculated.

\*\* Side thread for workpiece stop

# Table of jaws standard

## Gripper jaw high

The high gripper jaw was developed for even better accessibility to the workpiece from all sides. The workpiece is held higher than with the standard PMC-HMC gripper jaws. The length of the interfering contour in the gripper serration is strongly minimised, which leads to a reduced clamping force. Nevertheless, this jaw can be used on both sides to maximise the clamping range of the clamping systems.

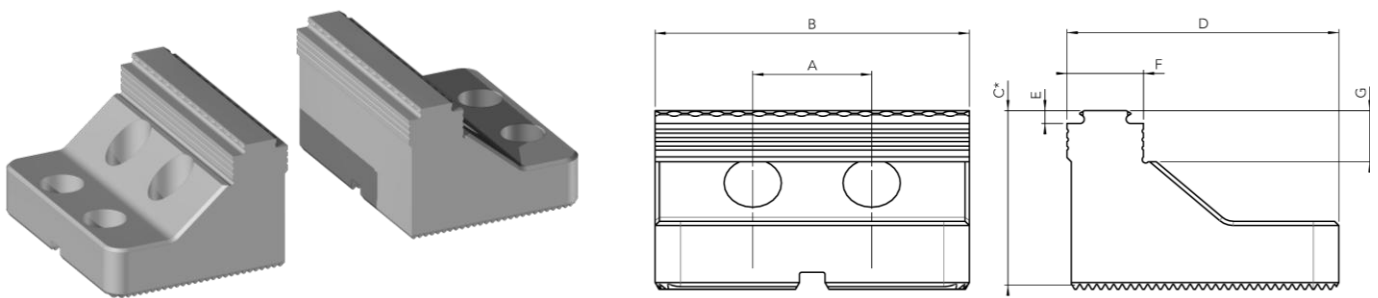

Order code	837300- B34	837300- B40	837300- B50	837300- B60	837300- B74	837300- B100	837300- B120	837300- B150
<b>A Series of jaws</b>	618	618	628	828	828	860	860	860
<b>B Jaw width</b> [mm]	34	40	50	60	74	100	120	150
<b>C Jaw height*</b> [mm]	32	32	32	41	41	42	42	42
<b>D Jaw length</b> [mm]	30	30	30	58	58	60	60	60
<b>E Gripper height</b> [mm]	3	3	3	3	3	3	3	3
<b>F Step length</b> [mm]	12	12	12	18	18	20	20	20
<b>G Step height</b> [mm]	10	10	10	12	12	11	11	11
<b>Max. Clamping Force</b> [kN]	12	12	15	20	40	60	60	60

\* The jaw height is reduced by the gripping depth so that the actual height of the clamping system can be easily calculated.

# Table of jaws standard

## Combi Gripper jaw

The combi gripper jaw is characterised by different step heights for surface tensioning. Different step heights can be realised thanks to the interchangeable step supports. The click system makes it easy to replace the underlays and add further step heights to the clamping system. In addition to this function, grip serrations are also fitted on both sides.

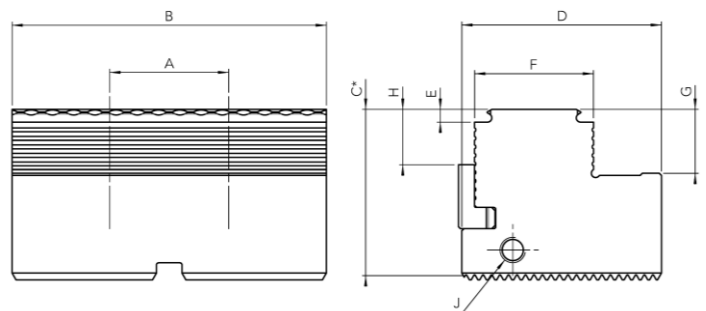
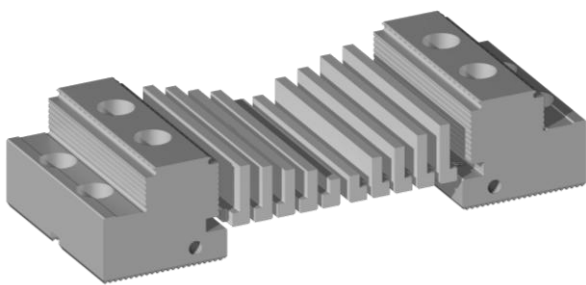

Order code	837350- B34	837350- B40	837350- B50	837350- B60	837350- B74	837350- B100	837350- B120	837350- B150
<b>A Series of jaws</b>	618	618	628	828	828	860	860	860
<b>B Jaw width</b> [mm]	34	40	50	60	74	100	120	150
<b>C Jaw height*</b> [mm]	28	28	28	39	39	40	40	40
<b>D Jaw length</b> [mm]	33	33	33	47	47	53	53	53
<b>E Gripper height</b> [mm]	3	3	3	3	3	3	3	3
<b>F Step length</b> [mm]	23	23	23	28	28	33	33	33
<b>G Step height fixed</b> [mm]	15	15	15	15	15	15	15	15
<b>H Step height replaceable</b> [mm]	6, 8, 11	6, 8, 11	6, 8, 11	6, 8, 11, 13, 18	6, 8, 11, 13, 18	6, 8, 11, 13, 18	6, 8, 11, 13, 18	6, 8, 11, 13, 18
<b>J Side thread**</b>	M5	M5	M5	M6	M6	M6	M6	M6

\* The jaw height is reduced by the gripping depth so that the actual height of the clamping system can be easily calculated.

\*\* Side thread for workpiece stop

# Table of jaws standard

## Gripper jaw height one-sided

The high one-sided gripper jaw has been specially developed for automated loading of the clamping systems by a robot. The smallest possible interfering contours of the jaw and the one-sided gripper serration enable reliable workpiece clamping, even over large series.

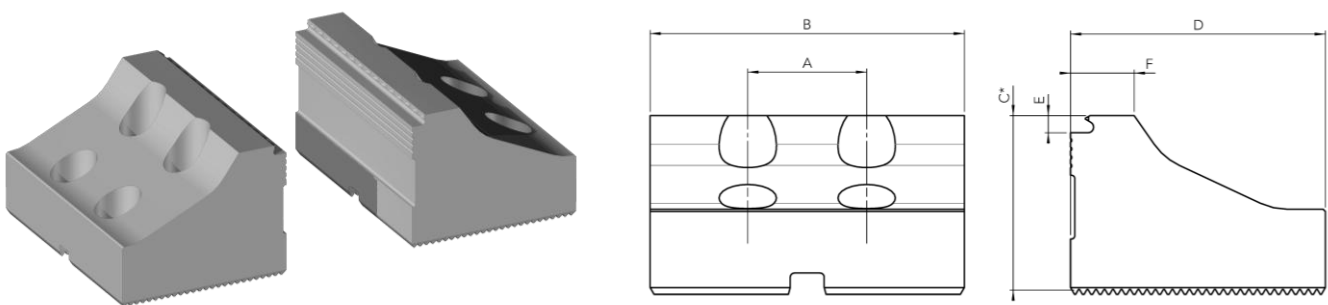

Order code	837380- B34	837380- B40	837380- B50	837380- B60	837380- B74	837380- B100	837380- B120	837380- B150
<b>A Series of jaws</b>	618	618	628	828	828	860	860	860
<b>B Jaw width</b> [mm]	34	40	50	60	74	100	120	150
<b>C Jaw height*</b> [mm]	32	32	32	41	41	42	42	42
<b>D Jaw length</b> [mm]	30	30	30	52	52	56	56	56
<b>E Gripper height</b> [mm]	3	3	3	3	3	3	3	3
<b>F Step length</b> [mm]	12	12	12	15	15	20	20	20

\* The jaw height is reduced by the gripping depth so that the actual height of the clamping system can be easily calculated.

# Table of jaws standard

## Stepped jaw high one sided deep

The stepped jaw high one sided deep has been specially developed for automated loading of the clamping systems by a robot. The smallest possible interfering contours of the jaw and the one sided clamping step enable process-reliable work-piece clamping, even over large series.

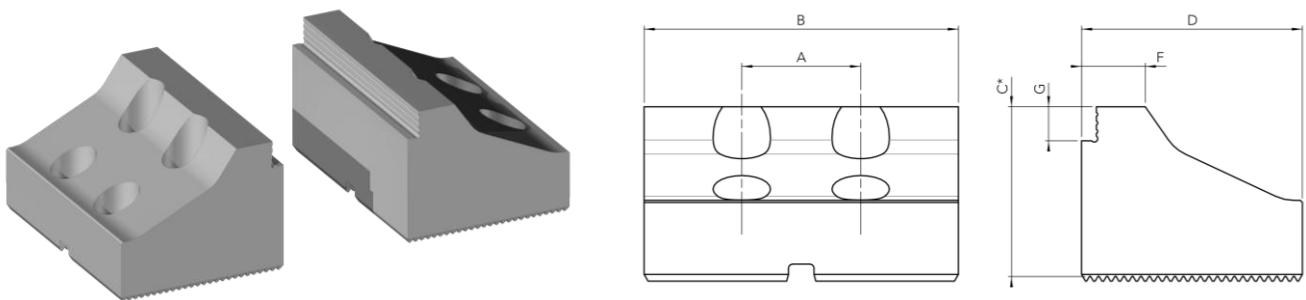

Order code	837400- B34	837400- B40	837400- B50	837400- B60	837400- B74	837400- B100	837400- B120	837400- B150
<b>A Series of jaws</b>	618	618	628	828	828	860	860	860
<b>B Jaw width</b> [mm]	34	40	50	60	74	100	120	150
<b>C Jaw height*</b> [mm]	30	30	30	41	41	46	46	46
<b>D Jaw length</b> [mm]	30	30	30	52	52	56	56	56
<b>F Step length</b> [mm]	12	12	12	15	15	15	15	15
<b>G Step height</b> [mm]	6	6	6	8	8	8	8	8

\* The jaw height is reduced by the gripping depth so that the actual height of the clamping system can be easily calculated.

# Table of jaws standard

## Step jaw low

The low stepped jaw was specially developed for the SC and LC series. The very short jaw design maximises the clamping system's clamping range. The step enables surface clamping of the workpiece without damaging it. The low shape allows the workpiece to be securely fixed in the lowest possible position.

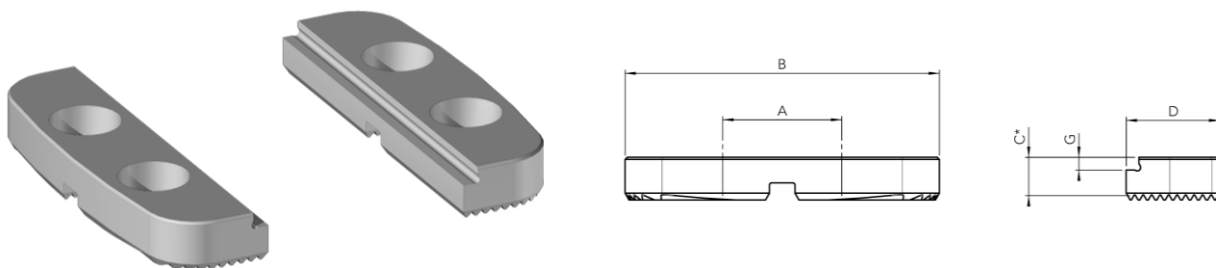

Order code	837410- B34	837410- B40	837410- B50	837410- B60	837410- B74	837410- B100	837410- B120	837410- B150
<b>A Series of jaws</b>	618	618	628	828	828	860	860	860
<b>B Jaw width</b> [mm]	34	40	50	60	74	100	120	150
<b>C Jaw height*</b> [mm]	7	7	7	9	9	11	11	11
<b>D Jaw length</b> [mm]	17	17	21	21	22	22	26	26
<b>G Step height</b> [mm]	3	3	3	3	3	3	3	3

\* The jaw height is reduced by the gripping depth so that the actual height of the clamping system can be easily calculated.

# Table of jaws standard

## Step jaw

The stepped jaw is the first choice when it comes to surface clamping on machined surfaces. The step enables a level insertion, and the clamping surfaces a strong fixation of the workpiece. The jaw has 2 sides with different step heights. These can be selected depending on the application.

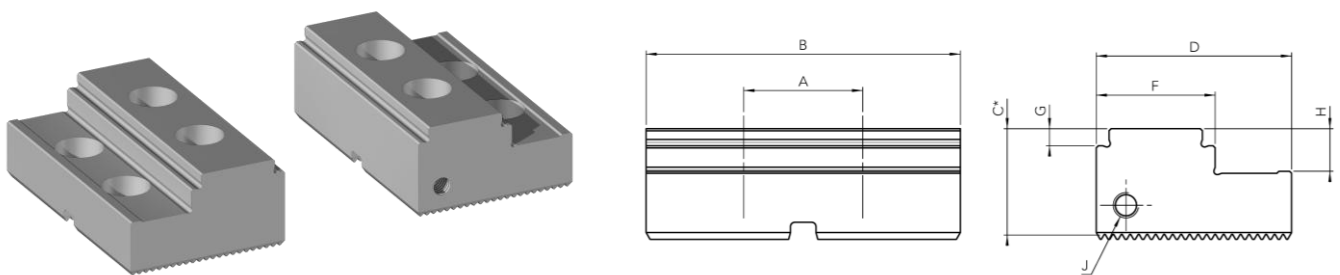

Order code	837450- B34	837450- B40	837450- B50	837450- B60	837450- B74	837450- B100	837450- B120	837450- B150
<b>A Series of jaws</b>	618	618	628	828	828	860	860	860
<b>B Jaw width</b> [mm]	34	40	50	60	74	100	120	150
<b>C Jaw height*</b> [mm]	16	16	16	25	25	29	29	29
<b>D Jaw length</b> [mm]	26	26	26	46	46	54	54	54
<b>F Step length</b> [mm]	20	20	20	28	28	28	28	28
<b>G Step height</b> [mm]	3	3	3	4	4	4	4	4
<b>H Step height 2</b> [mm]	9	9	9	10	10	10	10	10
<b>J Side thread**</b>	M5	M5	M5	M6	M6	M6	M6	M6

\* The jaw height is reduced by the gripping depth so that the actual height of the clamping system can be easily calculated.

\*\* Side thread for workpiece stop

# Table of jaws standard

## Step jaw high one-sided

The high one-sided stepped jaw has been developed for automated loading using robots. It has a higher step, which improves accessibility for the processing machine. The clamping point is also very short, which ensures accessibility with short tooling from all sides.

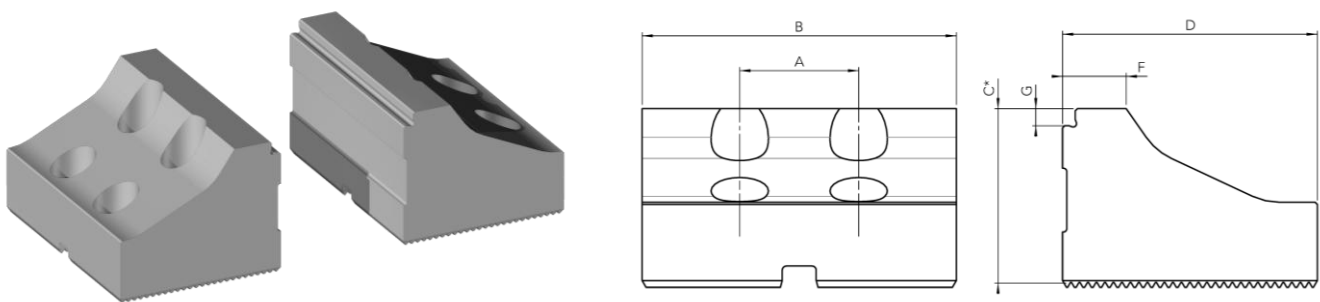

Order code	837480- B34	837480- B40	837480- B50	837480- B60	837480- B74	837480- B100	837480- B120	837480- B150
<b>A Series of jaws</b>	618	618	628	828	828	860	860	860
<b>B Jaw width</b> [mm]	34	40	50	60	74	100	120	150
<b>C Jaw height*</b> [mm]	32	32	32	41	41	42	42	42
<b>D Jaw length</b> [mm]	30	30	30	52	52	56	56	56
<b>F Step length</b> [mm]	12	12	12	15	15	20	20	20
<b>G Step height</b> [mm]	3	3	3	4	4	4	4	4

\* The jaw height is reduced by the gripping depth so that the actual height of the clamping system can be easily calculated.

# Table of jaws standard

## Prism jaw

The prism jaw is suitable for clamping round workpieces. The workpiece is inserted into two V-shaped grooves. The entire clamping force is transferred to the round workpiece through the jaw and then via the surfaces. The prism jaw has V-shaped grooves in both, the vertical and horizontal directions.

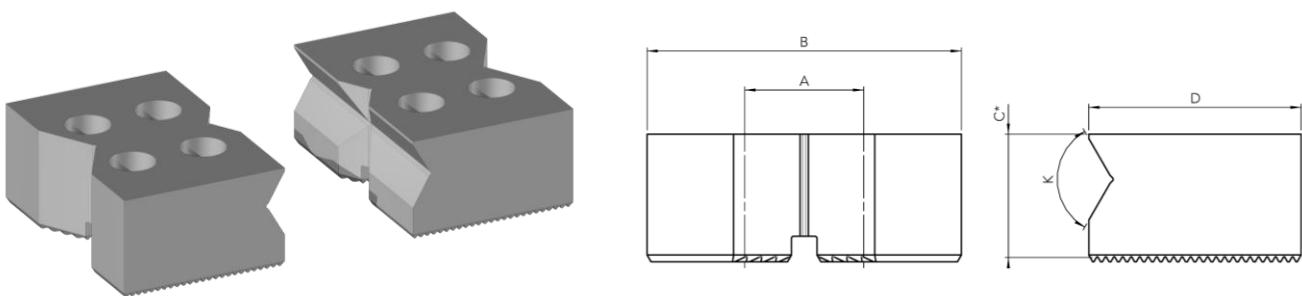

Order lcode		<b>837500- B34</b>	<b>837500- B40</b>	<b>837500- B50</b>	<b>837500- B60</b>	<b>837500- B74</b>	<b>837500- B100</b>	<b>837500- B120</b>	<b>837500- B150</b>
<b>A Series of jaws</b>		618	618	628	828	828	860	860	860
<b>B Jaw width</b>	[mm]	34	40	50	60	74	100	120	150
<b>C Jaw height*</b>	[mm]	21	21	21	29	29	35	35	35
<b>D Jaw length</b>	[mm]	20	20	20	50	50	50	50	50
<b>K Prism angle</b>	[°]	120	120	120	120	120	120	120	120
<b>Horizontal Ø-range</b>	[mm]	7.5-28	7.5-28	7.5-28	10-38	10-38	10-38	10-38	10-38
<b>Vertical Ø-range</b>	[mm]	7.5-37	7.5-47	7.5-47	10-66	10-66	12-85	12-85	12-85

\* The jaw height is reduced by the gripping depth so that the actual height of the clamping system can be easily calculated.

# Table of jaws standard

## Soft jaw Aluminium

The aluminium soft jaw is used for contour clamping of soft materials. Thanks to the easy-to-process aluminium, the negative contours of the workpieces can be milled into the jaw. This creates optimum clamping surfaces for each workpiece, which leave no marks on the workpiece.

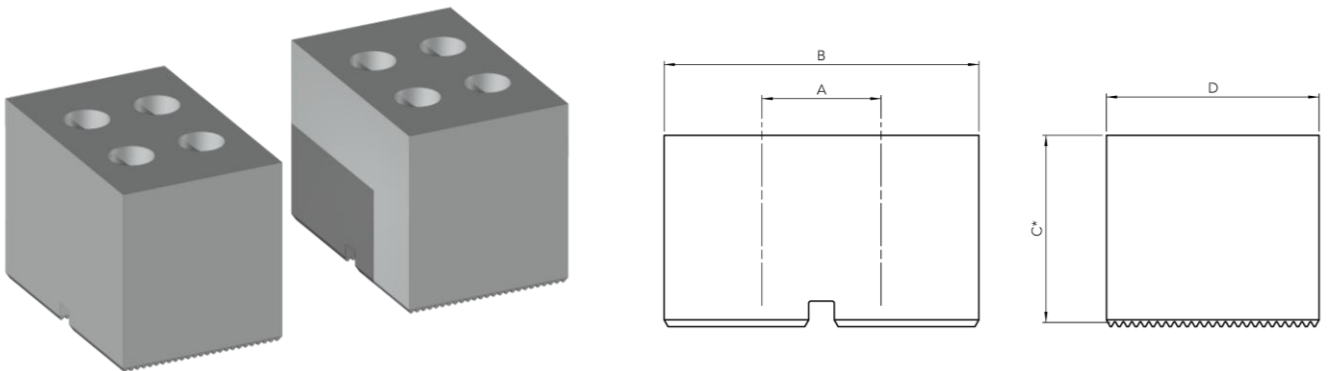

Order code		<b>837702- B34</b>	<b>837702- B40</b>	<b>837702- B50</b>	<b>837702- B60</b>	<b>837702- B74</b>	<b>837702- B100</b>	<b>837702- B120</b>	<b>837702- B150</b>
<b>A</b>	<b>Series of jaws</b>	618	618	628	828	828	860	860	860
<b>B</b>	<b>Jaw width</b>	<b>[mm]</b> 34	40	50	60	74	100	120	150
<b>C</b>	<b>Jaw height*</b>	<b>[mm]</b> 39	39	44	49	54	69	69	69
<b>D</b>	<b>Jaw length</b>	<b>[mm]</b> 32	35	35	50	50	60	60	60

\* The jaw height is reduced by the gripping depth so that the actual height of the clamping system can be easily calculated.

# Table of jaws standard

## Soft jaw Steel

The soft jaw steel is suitable for the in-house production of clamping jaws. Negative contours or holders for other clamping elements can be easily incorporated into the steel jaws. As a result, this type of jaw can be used for a wide variety of tasks and workpieces. Subsequent hardening is possible to maximise the wear resistance of the jaws.

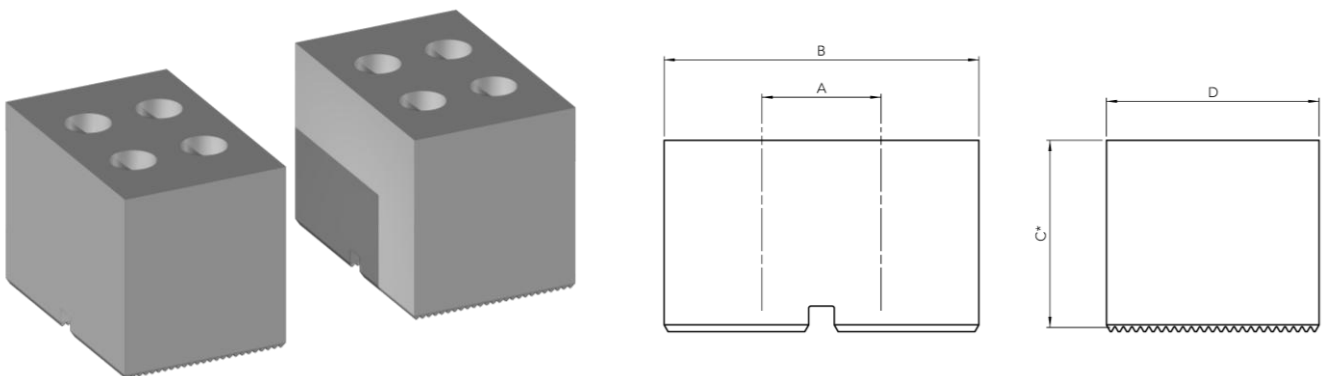

Order code		<b>837703- B34</b>	<b>837703- B40</b>	<b>837703- B50</b>	<b>837703- B60</b>	<b>837703- B74</b>	<b>837703- B100</b>	<b>837703- B120</b>	<b>837703- B150</b>
<b>A</b>	<b>Series of jaws</b>	618	618	628	828	828	860	860	860
<b>B</b>	<b>Jaw width</b>	<b>[mm]</b> 34	40	50	60	74	100	120	150
<b>C</b>	<b>Jaw height*</b>	<b>[mm]</b> 39	39	44	49	54	69	69	69
<b>D</b>	<b>Jaw length</b>	<b>[mm]</b> 32	35	35	50	50	60	60	60

\* The jaw height is reduced by the gripping depth so that the actual height of the clamping system can be easily calculated.

# Applications

## Standard jaws

Thanks to the standardised Gremotool jaw system, the jaws on the clamping devices can be easily replaced. This means that clamping devices do not have to be removed from the machining table in order to achieve flexibility. The savings in set-up times are noticeable after a short time.

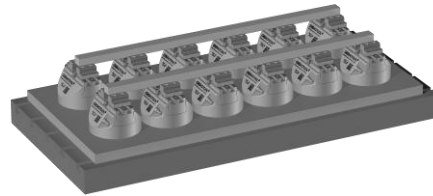

**Jaw:** 12x 837250-B60  
**Clamping device:** 12x PMC-60

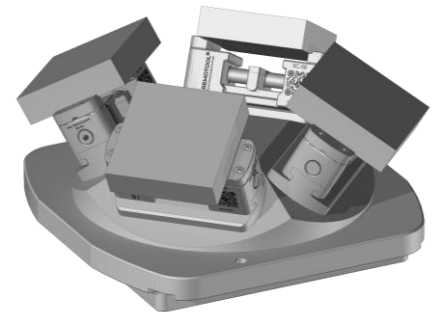

**Jaw:** 4x 837150-B50  
**Clamping device:** 4x SC-50

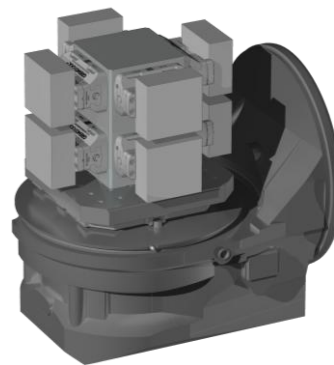

**Jaw:** 8x 837150-B60  
**Clamping device:** 8x LC-60



**Jaw:** 837500-B74  
**Clamping device:** LC-74 integrated ITS-148

# Applications

## Special jaws

If more specialised geometries such as shafts, cast workpieces or forged parts need to be machined, Gremotool solutions are then available. The negative contours or fixtures for additional clamping elements can be realised in soft jaws.

Gremotool designs and supplies customised jaws. Please get in touch with us.

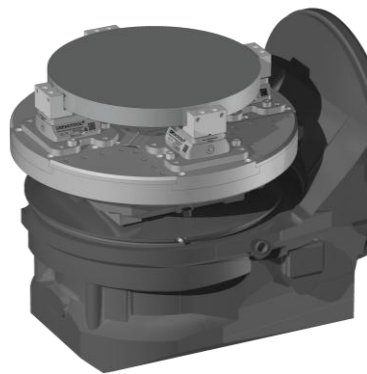

**Jaw:** 2x 837703-B74  
**Clamping device:** 2x VC-74



**Jaw:** 2x 837703-B120  
**Clamping device:** 2x HMC-120

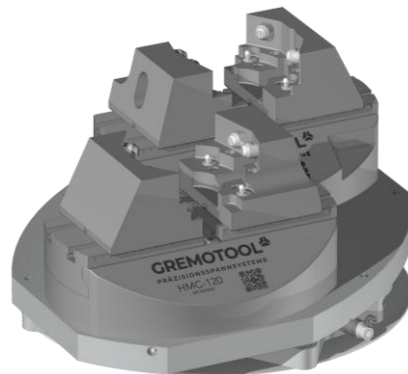

**Jaw:** 2x 837703-B120  
**Clamping device:** 2x HMC-120

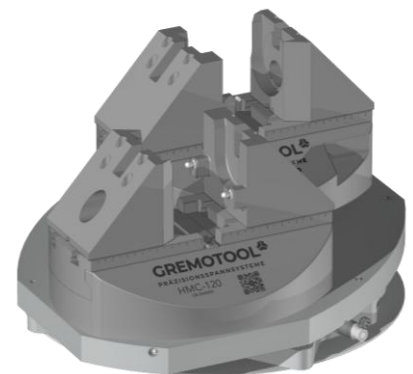

**Jaw:** 2x 837703-B120  
**Clamping device:** 2x HMC-120

# Accessories

## T-nuts & Supports Combi-Gripper jaws

T-nuts are required to ensure that the jaws can be securely fixed on the pneumatic and hydraulic centre clamps of the PMC and HMC series. We also offer the T-nuts to match the clamps. The set contains 4 T-nuts.

No additional T-nuts are required for the LC, SC, and VC series.

**T-slot nut set suitable for:**

PMC-50	HMC-50
PMC-60, PMC-60I, PMC-74, PMC-100, PMC-120	HMC-60, HMC-60I, HMC-74, HMC-100, HMC-120

## Combi-Gripper jaw Supports Pair

Replacement supports can be ordered for the combination jaws. The following dimensions are available. The order code is based on the following:

837 360- B\_\_\_/\_\_\_

example: 837 360-B74/8

Suitable for:	Step depth				
	6	8	11	13	18
837350-B34	✓	✓	✓		
837350-B40	✓	✓	✓		
837350-B50	✓	✓	✓		
837350-B60	✓	✓	✓	✓	✓
837350-B74	✓	✓	✓	✓	✓
837350-B100	✓	✓	✓	✓	✓
837350-B120	✓	✓	✓	✓	✓
837350-B150	✓	✓	✓	✓	✓

# Accessories

## Gremotool TCF

### **Gremotool Turbo Chip Fan $\varnothing 68$ , $\varnothing 117$ and $\varnothing 166$**

With the Turbo Chip Fan from Gremotool, the machining centre can automatically remove residues of chips and cooling lubricants from the workpiece, the clamping device and the machining table after the manufacturing process. This allows the operator, whether human or robot, to remove a cleaned workpiece from the machining area of the machine tool without having to wash it down beforehand with an air or water jet. When using robots, this cleaning of chips is essential, as the chips have a negative impact on process stability. The risk of chips becoming jammed during reloading is significantly reduced.

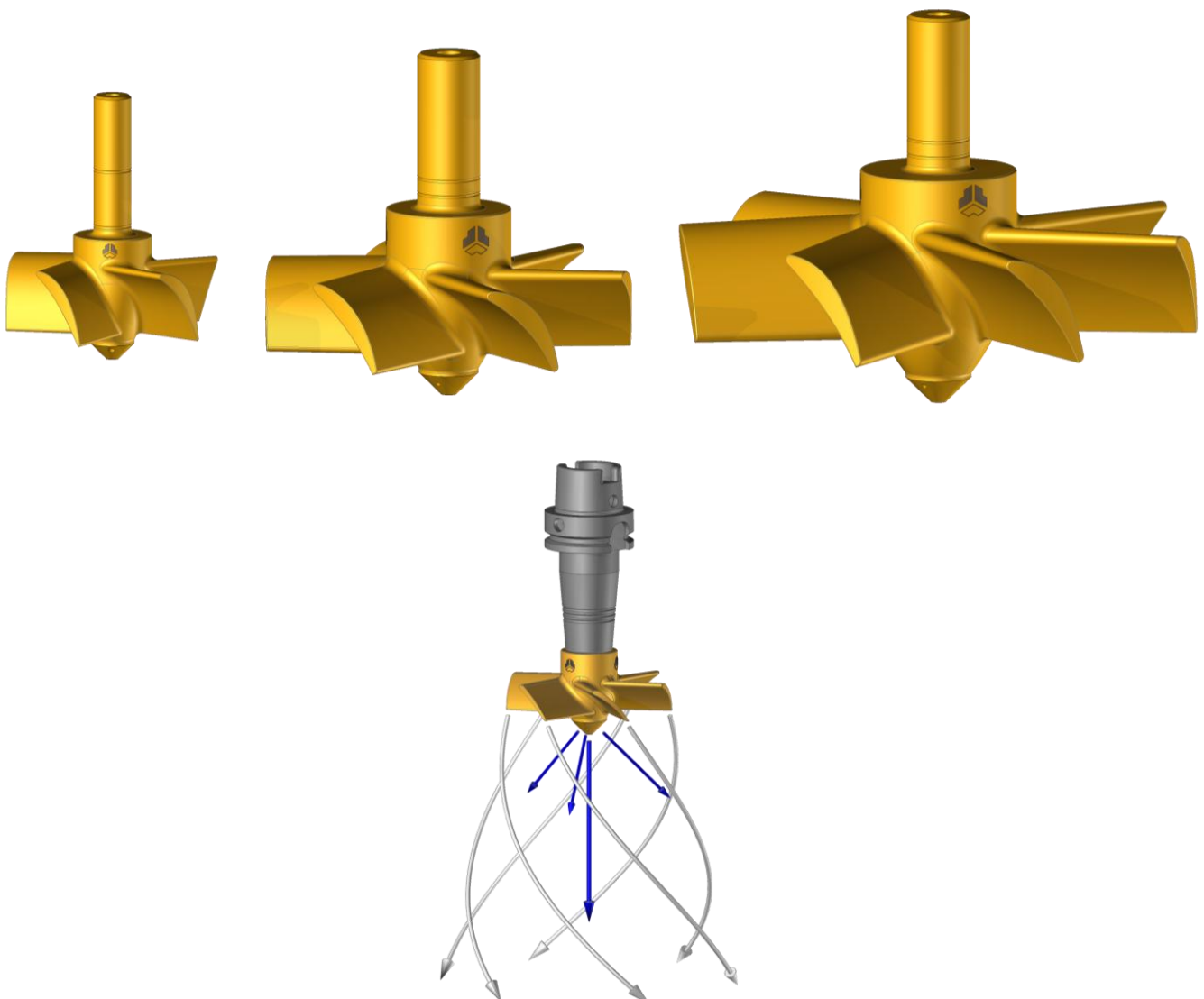

# Accessories

## Gremotool CLT-filter system

### **Gremotool Cooling Liquid Treatment (CLT):**

- Can be easily integrated into existing cooling lubricant systems
- Optimal addition to belt filters and magnetic separators
- Filtration of steel, cast iron, graphite, aluminium, copper, brass, tool abrasion and grinding dust
- Improves surface quality in metalworking
- Extends the service life of machining tools and cooling lubricants
- Oil and sludge absorbing filter unit
- Reduces wear on system components (valves, nozzles, pumps, rotary joints)
- No external power supply
- Extremely easy to operate and maintain
- Reduces your operating and disposal costs



# Accessories

## Gremotool PAT Toolboy Vice

### Gremotool PAT Toolboy Vice

Gremotool has added a new universal adapter to pwb's machining tool mounting aid. The PAT is a vice that can be attached to the base of the ToolBoy. This allows it to be used flexibly for clamping workpieces. The interaction of both elements allows the PAT to be swiveled, just like the machining tool holders. Various machining tools and workpieces can be clamped in the vice with magnetic protective jaws without damage and without having to change the adapter.

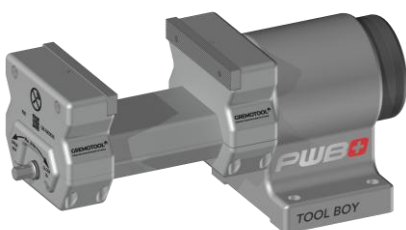
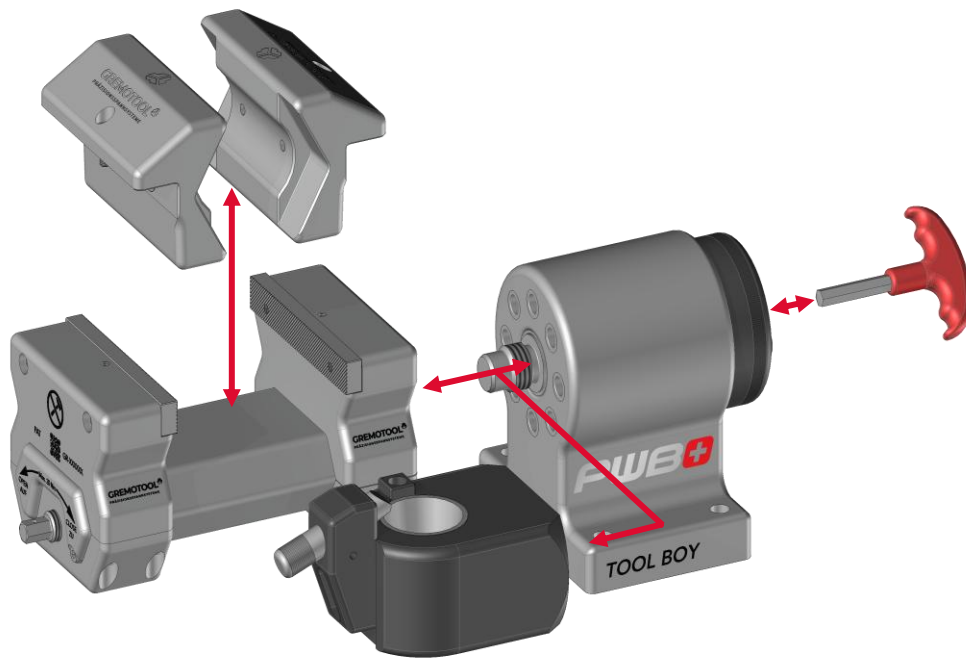

0° swiveled on base module

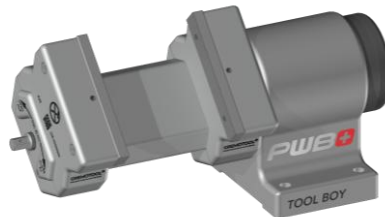

+/-45° swiveled on base module

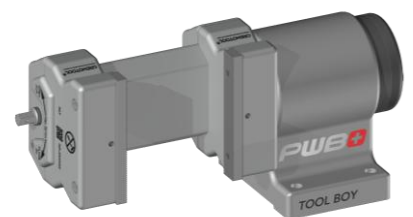

+/-90° swiveled on base module

# Regulations

MR 2023/1230 – MD 2006/42/EC

## **Operating instructions:**

Detailed instructions are essential for the correct operation, maintenance and troubleshooting of the system. They must contain all safety-related information. Operating instructions will be available for the individual components. However, the system itself, i.e. the interaction of the individual components used, must be evaluated in a system operating manual.

## **CE Declaration of Incorporation:**

The CE marking confirms that the system complies with European safety and health requirements. This declaration is particularly important for machines in the EU.

## **Risk and safety assessment:**

Before commissioning, a comprehensive analysis must be carried out to identify potential hazards and define appropriate protective measures.

## **Software update:**

Regular updates ensure optimal performance and security improvements. They may include new features and bug fixes.

## **Cyber security:**

In networked systems, data and access must be protected to prevent attacks, manipulation or unauthorised access.

## **Remote maintenance:**

Modern systems often offer remote monitoring and maintenance capabilities, which can reduce down-time and lower maintenance costs.







## Imprint

Gremotool GmbH  
Wilerstrasse 3  
CH-9200 Gossau  
Schweiz

[www.gremotool.ch](http://www.gremotool.ch)  
[info@gremotool.ch](mailto:info@gremotool.ch)  
+41 (0)71 930 03 90

Our general terms and conditions apply, which can be accessed at [www.gremotool.ch](http://www.gremotool.ch)

Further catalogues can be downloaded from the website [www.gremotool.ch](http://www.gremotool.ch)

Commercial Register:  
UID-Nr. CHE-498.310.590

This document is protected by copyright. All rights reserved. Any use, even partial use, in particular publication, duplication, distribution, reproduction, processing and/or modification, requires the prior written authorisation of Gremotool GmbH. Misprints, errors, and technical changes reserved.

Publication Dec. 2025, 3rd Edition

